

470, 700, 490S, 495S, 800, 801

Remote Lightheads

TOMAR's remote strobe lightheads are designed to be used with all TOMAR's strobe or NEOBE® remote power supplies. TOMAR's remote strobe lightheads feature 360° Lexan® lenses. The model 801 remote strobe head features a low profile Lexan® MINI LITE lens and a lightweight base that can be flange mounted, 1/2" pipe mounted, or surface mounted. The model 800 remote strobe head features a medium profile Lexan® lens and a lightweight base that can be flange mounted, 1/2" pipe mounted, or surface mounted. All models have replaceable plug-in lamps except for the 470-R1 and 700-R1 which are hermetically sealed assemblies.



470-R1
Strobe

700-R1
Strobe

490S-R1
Strobe

801-RL
Strobe

800-RL
Strobe

Ordering Information

Please specify lens colors and model number when ordering. Available colors are Amber, Blue, Clear, Green, Purple(except 490S-R1) and Red.

| Model No. | Description |
|------------|---|
| 470-R1 | Hermetically sealed, 6" leads, 3.25" high |
| 700-R1 | Hermetically sealed, flange mount, 3.25" high |
| 490S-R1 | Low profile, 1/2" pipe hub, 6" leads, 5" high |
| 495S-R1 | Low profile, 1/2" male thread mount, 5" high |
| 490S-RL-20 | Low profile, 1/2" pipe hub, 20' cable, 5" high |
| 495S-RL-20 | Low profile, 1/2" male thread, 20' cable, 5" high |
| 801-RL | Pipe mount, 6" leads |
| 801-RL-WP | Pipe mount, 6" leads, waterproof connector |
| 801-RL-15 | Pipe mount, 15' cable |
| 800-RL | Pipe mount, 6" leads |
| 800-RL-WP | Pipe mount, 6" leads, waterproof connector |
| 800-RL-15 | Pipe mount, 15' cable |

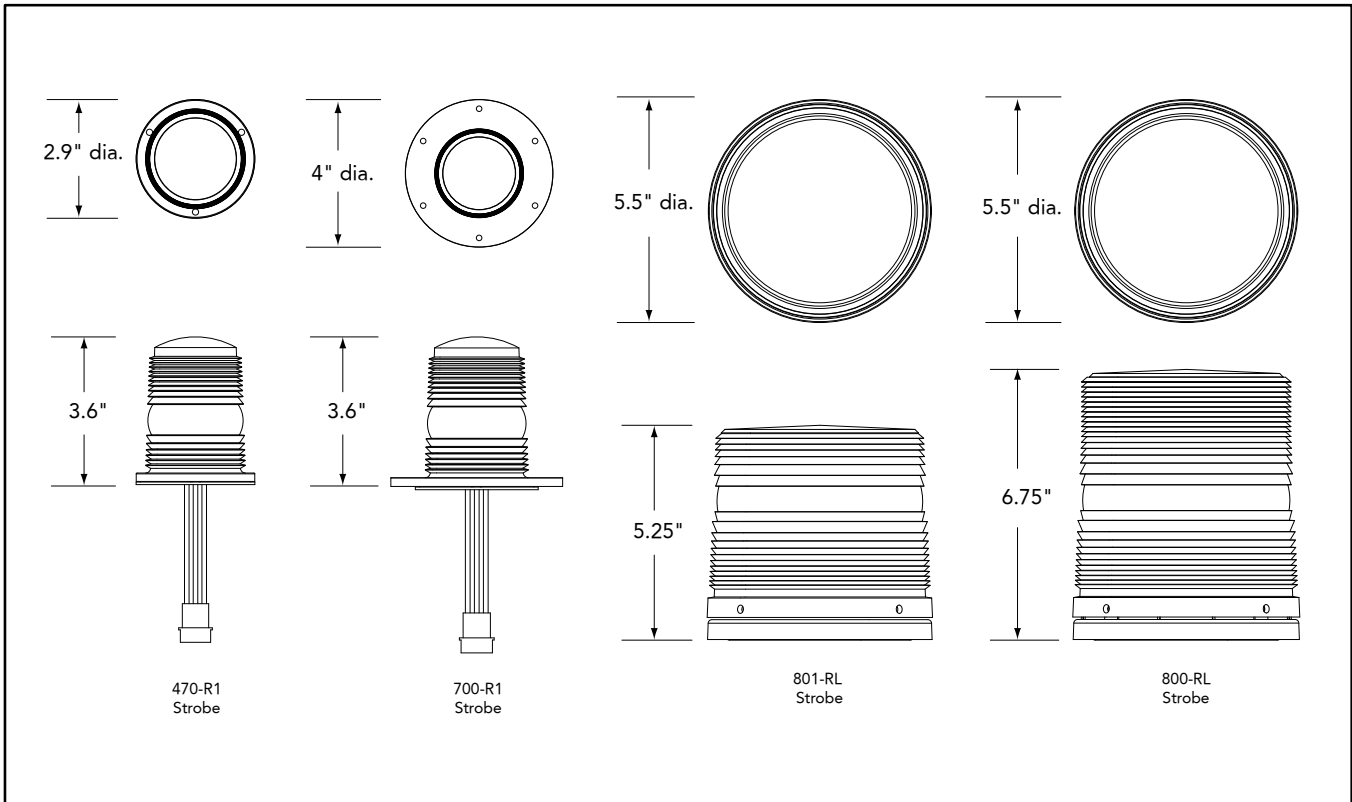

Specifications

| Item | Description |
|-----------------|--|
| Lamp Type | 470-RL xenon strobe lamp (models 800, 801) 3001 xenon strobe lamp (model 490-R1) |
| Size and Weight | 3.6" tall x 2.9" dia. (99.4mm x 73.7mm) -- model 470 5.0" tall x 3.0" dia. (127mm x 76.2mm) -- model 490 3.6" tall x 4.0" dia. (99.4mm x 101.6mm) -- model 700 5.25" tall x 5.5 dia. (133mm x 140mm) -- model 801 6.75" tall x 5.5 dia. (171mm x 140mm) -- model 800 |

Available Options

NOTE: All "/" options are factory installed only.

| Model No. | Description |
|---------------|---|
| 700-DC | Clear lens dust cover (model 700-RL) |
| /LBO-MINI | 180° lens blackout segment (models 470, 490, 495, 700) |
| 802-03 | Clear lens dust cover (model 801) |
| 1250-03 | Clear lens dust cover (model 800) |
| /LBO-MINILITE | Lens blackout segment 180° (model 801) |
| /LBO-MAXI | Lens blackout segment 180° (model 800) |
| TBO-MAXI | Top lens blackout segment (models 800, 801) |
| G802 | Heavy duty guard (model 801) |
| G800 | Heavy duty guard (model 800) |
| 800-R1-BASE | Base and lamp assembly including lamp (models 800, 801) |
| 800-FLG | Flange mounting ring (models 800, 801) |

Sharp Communication, Inc. • 3403 Governors Drive • Huntsville, AL 35805
800.548.2484 • 256.533.2484 • www.SharpCom.com